

DCDC

Title		
Size	Number	Revision
A4		
Date:	11/22/2024	Sheet of
File:	F:\项目 \.POWER.SchDoc	Drawn By:

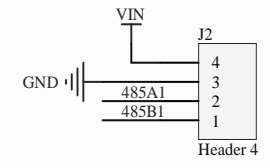

电平转换

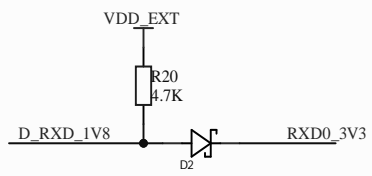
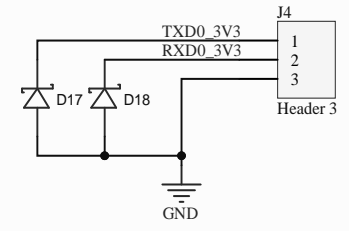
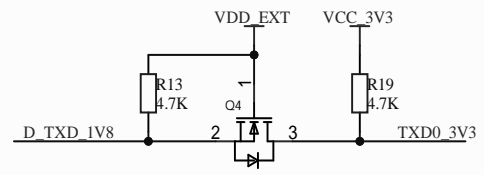
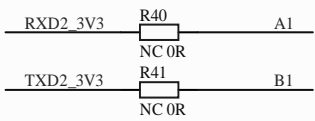
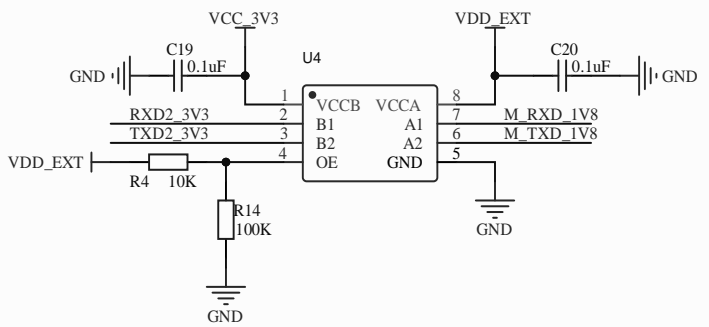
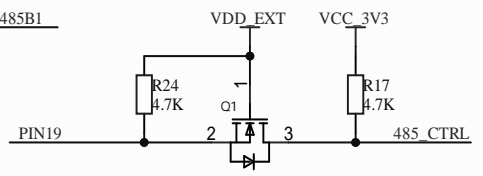
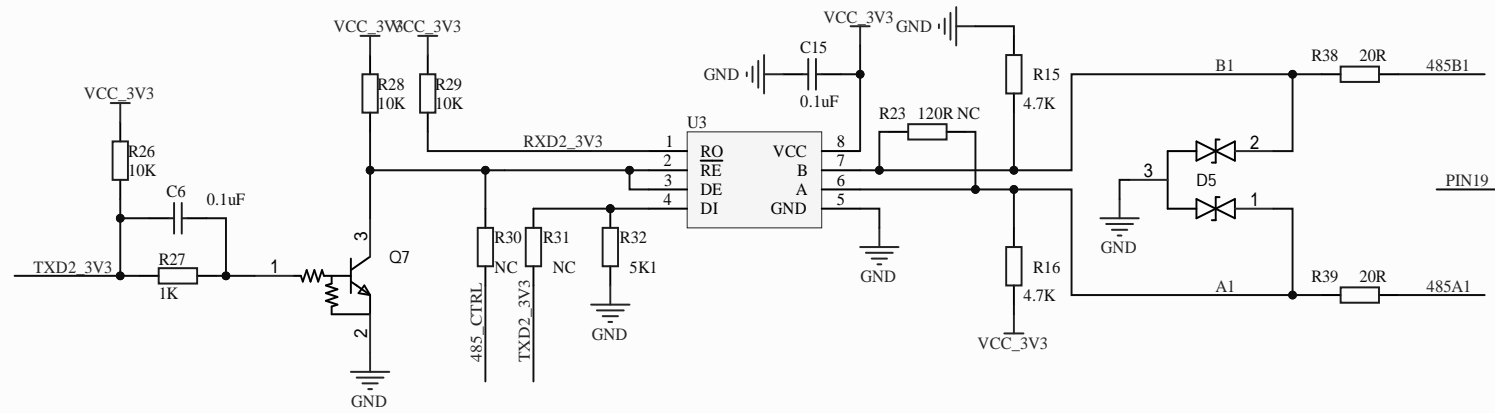

RS485

Title		
Size	Number	Revision
A4		
Date:	11/22/2024	Sheet of
File:	F:\项目\...\RS3485.SchDoc	Drawn By:

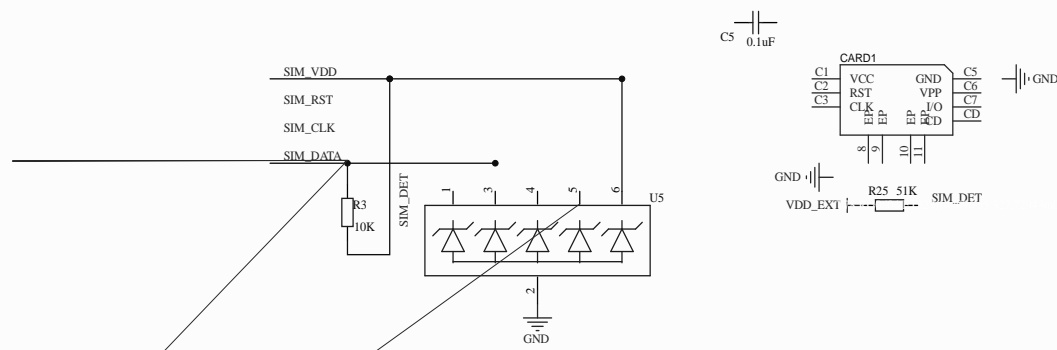

NANO SIM

Title		
Size	Number	Revision
A3		
Date:	11/22/2024	Sheet of
File:	F:\项目1\NANO SIMCARD.SchDoc	Drawn By: